

CX250C
CX250C LR
Tier 4
Crawler Excavator

SERVICE MANUAL

Part number 84402826

1st edition English
August 2011





Section

1001

Safety, general information and standard torque data

CONTENTS

GENERAL INFORMATION.....	3
Safety.....	4
ROPS Judgment Method.....	6
Standard Torque Data For Cap Screws And Nuts.....	10

**Thanks very much for your reading,
Want to get more information,
Please click here, Then get the complete
manual**

JustClickHere 

NOTE:

**If there is no response to click on the link above,
please download the PDF document first, and then
click on it.**

**Have any questions please write to me:
admin@servicemanualperfect.com**

Safety, general information and standard torque data

GENERAL INFORMATION

CLEANING

Clean all metal parts except bearings, in a suitable cleaning solvent or by steam cleaning.

Do not use caustic soda for steam cleaning.

After cleaning, dry and put oil on all parts.

Clean oil passages with compressed air.

Clean bearings in a suitable cleaning solvent, dry the bearings completely and put oil on the bearings.

INSPECTION

Check all parts when the parts are disassembled.

Replace all parts that have wear or damage.

Small scoring or grooves can be removed with a hone or crocus cloth.

Complete a visual inspection for indications of wear, pitting and the replacement of parts necessary to prevent early failures.

BEARINGS

Check bearings for easy action.

If bearings have a loose fit or rough action replace the bearing.

Wash bearings with a suitable cleaning solvent and permit to air dry.

DO NOT DRY BEARINGS WITH COMPRESSED AIR.

NEEDLE BEARINGS

Before you press needle bearings in a bore always remove any metal protrusions in the bore or edge of the bore.

Before you press bearings into position put petroleum jelly on the inside and outside diameter of the bearings.

GEARS

Check all gears for wear and damage.

Replace gears that have wear or damage.

Oil seals, O-rings and gaskets.

Always install new oil seals, O-rings and gaskets.

Put petroleum jelly on seals and O-rings.

SHAFTS

Check all shafts that have wear or damage.

Check the bearing and oil seal surfaces of the shafts for damage.

SERVICE PARTS

Always install genuine Case service parts.

When ordering refer to the

Parts Catalogue for the correct part number of the genuine Case replacement items.

Failures due to the use of other than genuine Case replacement parts are not covered by warranty.

LUBRICATION

Only use the oils and lubricants specified in the Operator's or Service Manuals.

Failures due to the use of non-specified oils and lubricants are not covered by warranty.

Safety, general information and standard torque data

Safety

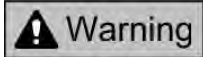

This symbol means ATTENTION! BECOME ALERT! YOUR SAFETY IS INVOLVED. The message that follows the symbol contains important information about safety. Carefully read the message. Make sure you fully understand the causes of possible injury or death.

To prevent injury always follow the Warning, Caution and Danger notes in this section and throughout the manual. Put the warning tag shown below on the key for the key switch when servicing or repairing the machine. One warning tag is supplied with each machine. Additional tags are available from your service parts supplier.

⚠ WARNING

Read the operator's manual to familiarize yourself with the correct control functions.

⚠ WARNING

Operate the machine and equipment controls from the seat position only. Any other method could result in serious injury.

⚠ WARNING

This is a one man machine, no riders allowed.

⚠ WARNING

**Before starting engine, study Operator's Manual safety messages.
Read all safety signs on machine.
Clear the area of other persons.
Learn and practice safe use of controls before operating.
It is your responsibility to understand and follow manufacturers instructions on machine operation, service and to observe pertinent laws and regulations.
Operator's and Service Manuals may be obtained from your CASE dealer.**

⚠ WARNING

**If you wear clothing that is too loose or do not use the correct safety equipment for your job, you can be injured.
Always wear clothing that will not catch on objects.
Extra safety equipment that can be required includes hard hat, safety shoes, ear protection, eye or face protection, heavy gloves and reflector clothing.**

⚠ WARNING

When working in the area of the fan belt with the engine running, avoid loose clothing if possible, and use extreme caution.

⚠ WARNING

When doing checks and tests on the equipment hydraulics, follow the procedures as they are written. DO NOT change the procedure.

⚠ WARNING

When putting the hydraulic cylinders on this machine through the necessary cycles to check operation or to remove air from a circuit, make sure all people are out of the way.

⚠ WARNING

Use insulated gloves or mittens when working with hot parts.

Safety, general information and standard torque data

⚠ WARNING

Lower all attachments to the ground or use stands to safely support the attachments before you do any maintenance or service.

⚠ WARNING

Pin sized and smaller streams of hydraulic oil under pressure can penetrate the skin and result in serious infection.

If hydraulic oil under pressure does penetrate the skin, seek medical treatment immediately.

Maintain all hoses and tubes in good condition.

Make sure all connections are tight.

Make a replacement of any tube or hose that is damaged or thought to be damaged.

DO NOT use your hand to check for leaks, use a piece of cardboard or wood.

⚠ WARNING

When removing hardened pins such as a pivot pin, or a hardened shaft, use a soft head (brass or bronze) hammer or use a driver made from brass or bronze and a steel head hammer.

⚠ WARNING

When using a hammer to remove and install pivot pins or separate parts using compressed air or using a grinder, wear eye protection that completely encloses the eyes (approved goggles or other approved eye protectors).

⚠ WARNING

Use suitable floor (service) jacks or chain hoist to raise wheels or tracks off the floor.
Always block machine in place with suitable safety stands.

⚠ WARNING

When servicing or repairing the machine, keep the shop floor and operator's compartment and steps free of oil, water, grease, tools, etc.

Use an oil absorbing material and/or shop cloths as required.

Use safe practices at all times.

⚠ WARNING

Some components of this machine are very heavy.
Use suitable lifting equipment or additional help as instructed in this Service Manual.

⚠ WARNING

Engine exhaust fumes can cause death.

If it is necessary to start the engine in a closed place, remove the exhaust fumes from the area with an exhaust pipe extension.

Open the doors and get outside air into the area.

⚠ WARNING

When the battery electrolyte is frozen, the battery can explode if (1), you try to charge the battery, or (2), you try to jump start and run the engine.

To prevent the battery electrolyte from freezing, try to keep the battery at full charge.

If you do not follow these instructions, you or others in the area can be injured.

Safety, general information and standard torque data

ROPS Judgment Method

1. Purpose

Check against the ROPS judgment criteria to judge whether the machine satisfies the ROPS criteria or not. The weight and boom of the machine greatly effects whether the ROPS judgment criteria is satisfied or not. The ROPS test assumes that the weight being used is the weight of the machine when the maximum number of selectable options are mounted (as of 2009).

However, depending on the derivative machinery or the order details, the weight and boom position may differ from the assumed weight or position.

2. Criteria for judging whether a machine satisfies the ROPS criteria

1) Weight

The weight must not be over the weight shown below for each class.

If the weight is exceeded, there is a danger that the cab could be damaged and the operator could die or sustain a serious injury when the machine falls over.

If the weight exceeds the stipulated weight, the machine will not satisfy the ROPS criteria.

• Weight (C series model)

To satisfy the ROPS criteria, the weight must not be over the indicated weight. (The below weights are the weights indicated on the nameplate within the ROPS cab)

Machine body total weight	Class
31000 kg or less	CX250C CX250CLR CX300C
40000 kg or less	CX370C
50000 kg or less	CX470C

* The ROPS test assumes that the CX470C has a cage guard (alone).

• Weight (B series model)

To satisfy the ROPS criteria, the weight must not be over the indicated weight. (The below weights are the weights indicated on the nameplate within the ROPS cab)

Machine body total weight	Class
25000 kg or less	CX130B CX160B CX180B CX210B CX230B

Safety, general information and standard torque data

2) Boom position

⚠ WARNING

- If the machine has been modified so that the boom position has been lowered, the machine will not satisfy the ROPS criteria.
- It is necessary to consult with our company if it is possible that the boom's position has been lowered by modification.
- The extent to which a boom position has moved cannot be determined in the same way for all machines.

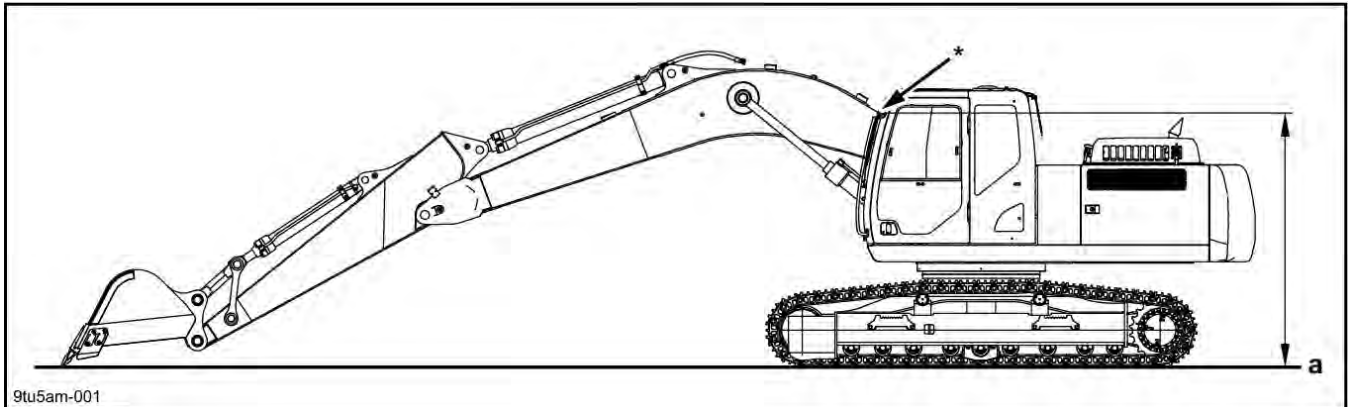

a | Ground point

With the tip of the bucket in contact with the ground surface at maximum work radius, if the position (*) in the diagram) that overlaps with the cab when viewed from the side is markedly lower than that of a standard machine (standard arm), the machine will not satisfy the ROPS criteria.

Also, with a machine body with a cab mounted that can withstand up to 31 tons, the effect of mounting a 24 ton machine, which is near the restriction weight, and a 21 ton machine to the same cab will not be the same.

Safety, general information and standard torque data

3. Prohibited items

- Modifications that reduce the strength of a platform that has a cab with a ROPS mounted to it. (Actions or modifications that reduce the functionality of the anchoring part at the left-rear of the cab)
- Modifications that effect the strength of the ROPS of a cab.

A forbidden all modifications (red part)	All modifications (grinding, welding, drilling holes, removing, etc.) are prohibited.
Allow under specified conditions (gray part)	Removal of parts is prohibited. Bar welding and making holes (up to diameter 20 mm) by drilling are possible.

[C series Cab]

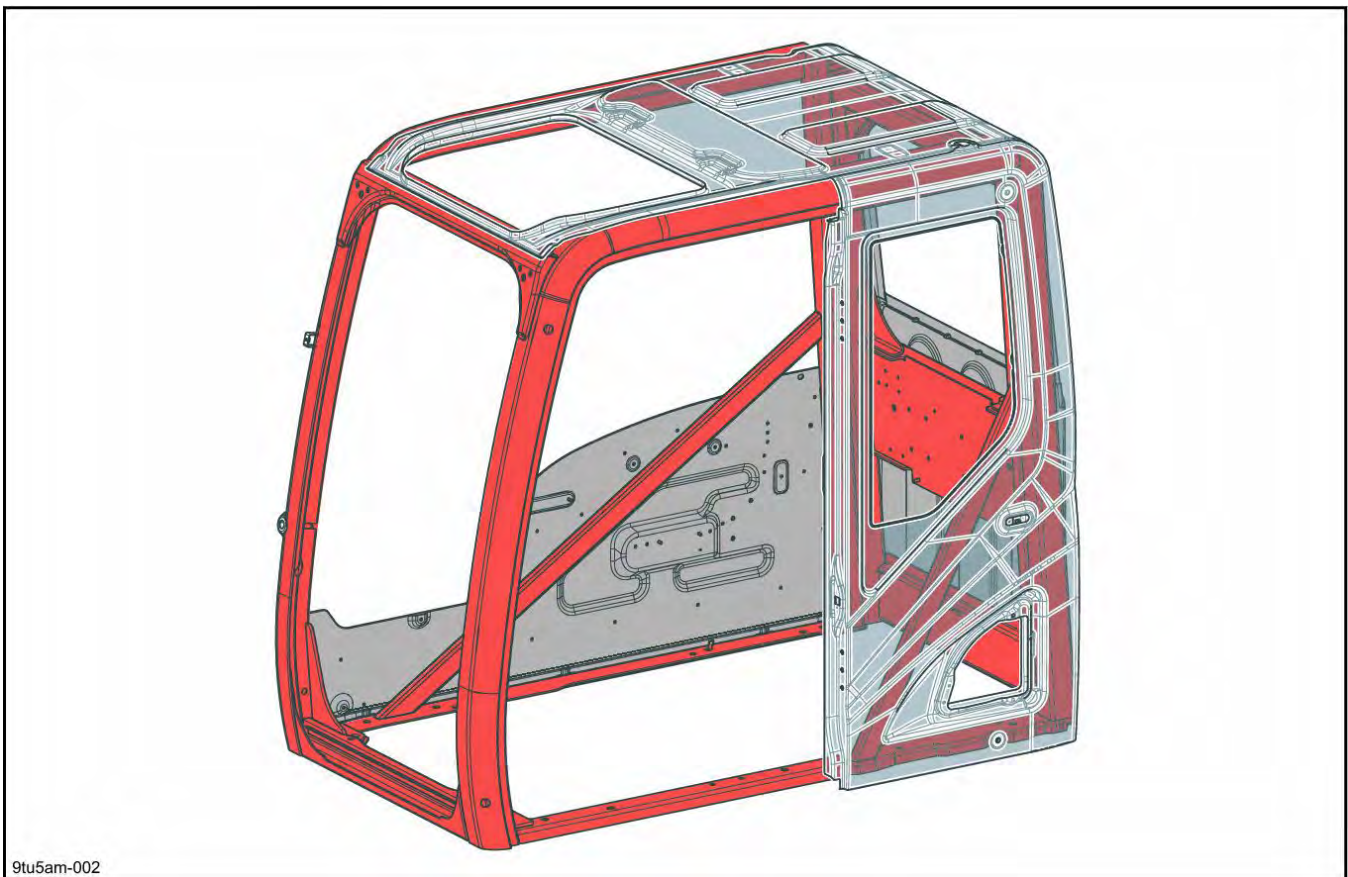

Safety, general information and standard torque data

[B series Cab]

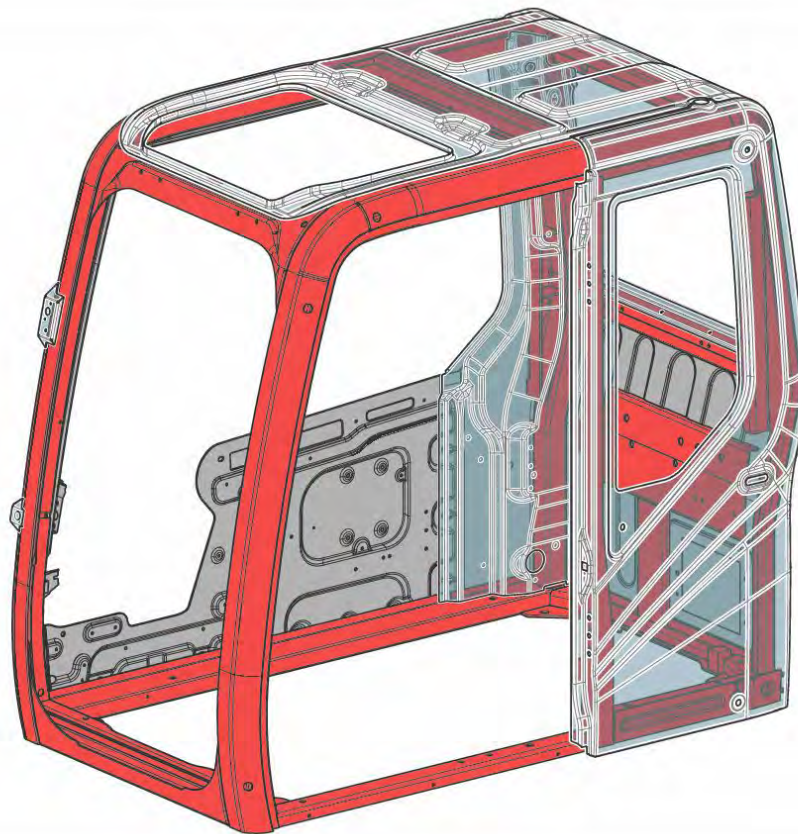

9tu5am-004

- In general, high cabs do not satisfy the ROPS criteria. (It is necessary to consult with our company to check if the high cab model satisfies the ROPS criteria.)

Safety, general information and standard torque data

Standard Torque Data For Cap Screws And Nuts

BOLT AND NUT TIGHTENING

- Tighten alternating between left and right and top and bottom so that uniform tightening force is applied.

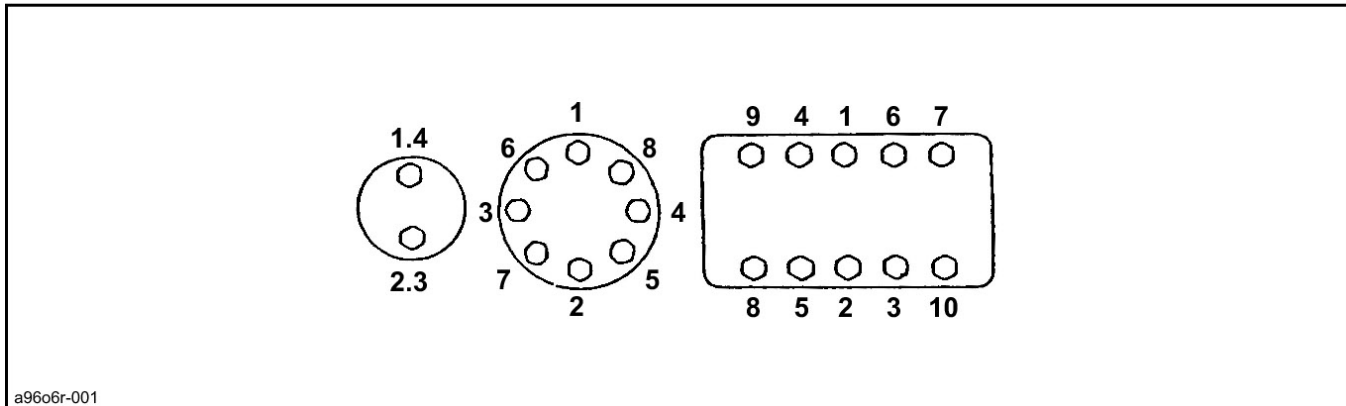

a96o6r-001

- If Loctite was used on a removed bolt (there is something white sticking to the bolt when it is removed), clean the old Loctite off with cleaning fluid, dry the bolt, then apply 2 - 3 drops of Loctite to the thread section of the bolt.

Torque table

Bolt nominal diameter (size)			M6	M8	M10	M12	M14	M16	M18	M20
Hexagon bolt	Wrench	[mm]	10	13	17	19	22	24	27	30
	Tightening torque	[N · m]	6.9	19.6	39.2	58.8	98.1	156.9	196.1	294.2
Hexagon socket head bolt	Wrench	[mm]	5	6	8	10	12	14	14	17
	Tightening torque	[N · m]	8.8	21.6	42.1	78.5	117.7	176.5	245.2	343.2



Section

1002A

Specifications

CONTENTS

Overall (CX250C).....	3
Main Data	3
Performance	3
Main Unit Dimensions	3
Engine	3
Cooling System	4
Upper Side Work System	4
Operating Device	5
Swing Units	5
Travel Lower Body	6
Hydraulic Equipment	6
Hydraulic Device	6
Control Valve and Cylinder	7
Capacities, Filters.....	7
Coolant and Oil Capacities	7
Hydraulic Oil Filters	7
Fuel Filter.....	7
Overall (CX250C LR).....	8
Main Data	8
Performance	8
Main Unit Dimensions	8
Engine	8
Cooling System	9
Upper Side Work System	9
Operating Device	10
Swing Units	10
Travel Lower Body	11
Hydraulic Equipment	11
Hydraulic Device	11
Control Valve and Cylinder	12
Capacities, Filters.....	12
Coolant and Oil Capacities	12
Hydraulic Oil Filters	12
Fuel Filter.....	12

Specifications

Overall (CX250C)

Main Data

Operating weight	24800 kg
Engine output	132.1 kW/2000 min ⁻¹
Bucket capacity	Heaped 1.10 m ³
	Leveled 0.76 m ³

Performance

Standard weight	13.5 kN	
Swing speed	10.6 min ⁻¹	
Travel speed	Low speed 3.5 km/h	
	High speed 5.5 km/h	
Maximum pulling force	201 kN	
Grade ability	70 % (35°)	
Ground pressure	49 kPa (600 mm grouser shoe)	43 kPa (700 mm grouser shoe)
	38 kPa (800 mm grouser shoe)	34 kPa (900 mm grouser shoe)

Main Unit Dimensions

Main unit length	5270 mm
Main unit width	3190 mm
Upper swing body width	2770 mm
Cab width	1000 mm
Main unit height	3020 mm
Swing radius (rear end)	2950 mm
Swing body rear end distance	2950 mm
Swing body rear section bottom height	1100 mm
Distance between tumblers	3840 mm
Overall track length	4650 mm
Overall track width	3190 mm
Distance between tracks	2590 mm
Track shoe width	600 mm (options 700 mm, 800 mm, 900 mm)
Minimum ground clearance	460 mm (to bottom of lower frame)

Engine

Name	Isuzu 4HK1X diesel engine
Model	4-cycle, water-cooled, overhead camshaft type, common rail system (electronic control), cooled EGR, with turbocharger (variable displacement type), DPD system
No. of cylinders - bore x stroke	4 - D115 mm x 125 mm
Total stroke volume	5.193 L
Maximum torque	621 N·m/1800 min ⁻¹
Starter	24 V 5.0 kW reduction type
Charging generator	24 V 50 A AC type
Battery	12 V 92 Ah/5 HR x 2

Specifications

Cooling System

Fan type	D650 mm, 7 blades, suction		
Radiator			
Fin type	Wavy		
Fin pitch	1.75 mm		
Oil cooler			
Fin type	Wavy		
Fin pitch	1.75 mm		
Intercooler			
Fin type	Triangular straight		
Fin pitch	1.75 mm		
Fuel cooler			
Fin type	Wavy		
Fin pitch	2.0 mm		

Upper Side Work System

Model	Backhoe attachment		
Components, dimensions, working dimensions			
Standard bucket capacity	Heaped 1.10 m ³ (Leveled 0.76 m ³)		
Bucket width	1260 mm		
Bucket width with side cutter	1360 mm		
Bucket weight with side cutter	856 kg		
Boom length	5850 mm		
Arm type	Standard (STD/HD) (3.00 m)	Long (STD/HD) (3.52 m)	Short (STD) (2.50 m)
Arm length	3000 mm	3520 mm	2500 mm
Bucket radius	1570 mm		
Bucket wrist angle	175°		
Maximum digging radius	10280 mm	10790 mm	9820 mm
Maximum digging radius at ground line	10100 mm	10620 mm	9630 mm
Maximum digging depth	6900 mm	7420 mm	6400 mm
Maximum vertical straight wall digging depth	6140 mm	6680 mm	5700 mm
Maximum digging height	9760 mm	10070 mm	9560 mm
Maximum dump height	6760 mm	7060 mm	6550 mm
Minimum swing radius at front	4030 mm	4050 mm	3980 mm
Height for minimum swing radius at front	7750 mm	7740 mm	7820 mm

Specifications

Operating Device

Operator's seat		
	Position	Left side
	Structure	Adjustable forward and back and up and down, reclining mechanism, with seat suspension
Cab		Sealed steel type, all reinforced glass
Levers and pedals		
	For travel use	Lever and pedal type (hydraulic pilot type) x 2
	For operating machine use	Lever type (hydraulic pilot type) x 2
Instruments and switches		
Work mode switchover		3 modes (SP/H/A)
	Travel mode switchover	Low-speed/high-speed switch type
	One-touch idle	Knob switch type
	Engine emergency stop	Switch type
Monitor device		
	Machine status display (full color liquid crystal)	
	Work mode select status	SP/H/A
Instruments (full color liquid crystal)		
	Fuel gauge	Bar graph and indicator
	Engine coolant temperature gauge	Bar graph and indicator
	Hydraulic oil temperature gauge	Bar graph and indicator
	Hour meter	Digital type
Machine status and warnings (full color liquid crystal and warning alarm) * has warning alarm		
Overheat (*) Battery charge (*) Electrical system abnormality (*) Refill fuel (*) Engine oil pressure (*) Refill coolant (*) Engine pre-heat Auto warm up Air cleaner (*) Anti-theft device triggered Engine system abnormality (*) Engine emergency stop (*)		
Illumination equipment		
	Working light	Tank front surface 24 V 70 W x 1
		Cab top 24 V 70 W x 2
		Boom up 24 V 70 W x 1
	Interior light	24 V 10 W x 1
Horn		Electric horn x 2
Other		Wiper with intermittent function, window washer, air conditioner, clock, rear view mirrors (left and right, total of 4)

Swing Units

Swing circle	Swing bearing type (with inner gear)
Swing hydraulic motor	Fixed displacement piston motor x 1
Reduction gear	Planetary gear 2-stage reduction gear
Swing parking brake	Mechanical lock (operational lever linkage type)

Specifications

Travel Lower Body

Travel hydraulic motor	Variable displacement piston motor x 2
Reduction gear	Planetary gear 2-stage reduction gear
Travel brake	Hydraulic lock
Parking brake	Mechanical lock (travel lever linkage type)
Track shoe	
Model	Assembly-type triple grouser shoe
No. of shoes (per side)	51
Shoe width	600 mm (options 700 mm, 800 mm, 900 mm)
Grouser height	26 mm
Link pitch	190 mm
Roller	
No. of upper rollers (per side)	2
No. of lower rollers (per side)	9
Track belt tension adjuster	Grease cylinder type (with cushion spring)

Hydraulic Equipment

Hydraulic Device

Hydraulic pump drive type	Direct engine link (no transmission)
Hydraulic pump	
Model	Double variable displacement piston pump x 1 Gear pump x 1
Discharge volume	Piston pump 2 x 234 L/min Gear pump 20 L/min
Pump control method	Simultaneous output full-horsepower control
Set pressure of main relief valve	34.3 MPa (36.8 MPa for pressure boost)
Set pressure of overload relief valve	29.4 MPa (boom down) 38.7 MPa (other)